



AN OSRAM BUSINESS

# THE PROJECTORS

FUTURE IS NOW



**SUPER  
SHARPY**



**MYTHOS**



**STORMY**



[WWW.THEPROJECTORS.IT](http://WWW.THEPROJECTORS.IT)

ENGLISH

## MYTHOS

THE PERFECT BALANCE BETWEEN  
A BEAM LIGHT AND A SPOTLIGHT

CODE C61391



The MYTHOS is a highly advanced form of hybrid light. It works in two different ways without compromising either. The MYTHOS is first of all an excellent 470 W lamp spotlight, which produces an outstanding fat light beam. Its completely redesigned optical unit makes it suitable for a wide range of applications. As a spotlight, it features a zoom that ranges from a minimum of 4° up to a maximum of 50°. In other words, it has an extraordinary 1 to 12 ratio.



It also features a wide range of projectable visual effects. There is a wheel with **18+1 fixed patterns** and a second wheel with **6 rotating dichroic gobos**. The quality of the projected light is truly extraordinary. Focusing is electronically controlled and the light beam is sharp, with **perfectly defined edges, from the first millimetres after the front lens right along its entire length.**

The **zoom** is a small masterpiece of micromechanical engineering. It is **optimized for focusing**, which is separate from that of the fixed and rotating gobos. Its movements are smooth, fast and very quiet.

There are also **two indexed rotating prisms**, which multiply the projected images. The first is an 8-facet prism for volumetric light scattering, and the second is a linear 4-facet prism that multiplies the image by fanning it out.

A completely new **visual graphic disc**, which turns in both directions at different speeds, may be superimposed on all the gobos, both in and out of focus. All these functions together make the MYTHOS a truly unique spotlight, which can be used for spectacular, powerful front lighting on the audience.

But that is not all! The MYTHOS is also an **extraordinary beam light**. Its optical unit allows you to switch to a **minimum fixed beam angle of just 0.5°**. A large, very dense, 170 mm-diameter light beam comes out the MYTHOS's front lens and remains parallel for its entire throw even at great distances. In this operating mode, the MYTHOS has **two-and-a-half times the brightness of a Sharpy**. The fixed gobos can be focused to shape the light beam in midair. The prisms may be inserted and set turning to fill the room with attractive effects.

The MYTHOS features a **gradual-insertion CMY system**, which is also equipped with fixed colors that may be overlapped and used to generate a **two-colored light beam**. CMY mixing ensures a very smooth transition from one color to another. **Two CTO filters** (3,200 K and 2,500 K) and **one**

**CTB filter** add infinite shades of color, especially pastel shades. A frost filter can be used both to soften the edges of the spotlight and to simulate a wash light. It has a high-precision dimmer and a variable frequency strobe effect.

MYTHOS is able to combine the graphic capabilities of a powerful spotlight with the midair effects of a powerful beam light, seamlessly into a single unit. The MYTHOS is a very versatile tool, which is useful in any situation and therefore an excellent investment. Clay Paky has yet again developed an exemplary light in terms of light output: it is able to generate a previously unimaginable number of lumens for each watt consumed.

### ROTATING GOBOS Ø 25.9 mm - img: Ø 13 mm



### GOBO WHEEL

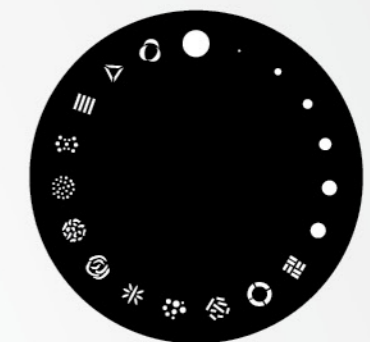

### CMY COLOR WHEELS

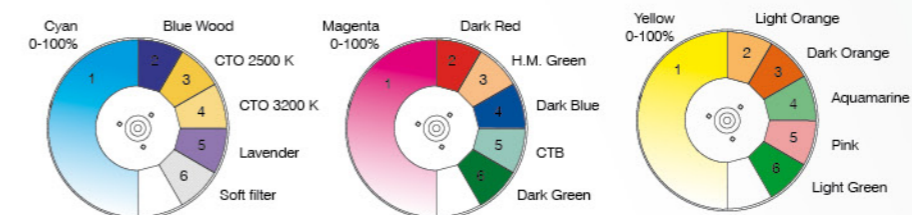

### WEIGHT AND DIMENSIONS (mm/inches)

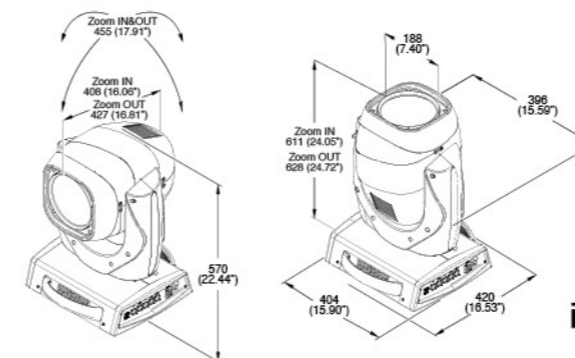

■ 31 kg (68.34 lbs)

### GRAPHIC DISC





# SUPERSHARPY

## SUPERSHARPY

THE LEGEND CONTINUES

CODE C61390



After the Sharpy's extraordinary worldwide success, Clay Paky is now launching the SUPERSHARPY, an ACL beam type moving head featuring a **470 watt**, 7,800 K lamp. If you have been amazed at how bright the Sharpy is, the SUPERSHARPY will leave you literally stunned. Its light beam is nothing short of **three times brighter**, with a far bigger difference than you would expect by simply comparing the rated wattage of the two lamps (470 vs 190). Thanks to this incredible output, the SUPERSHARPY's light reaches never-seen-before mid-air distances, making the SUPERSHARPY the first low-wattage beam light that can really challenge a searchlight.

However Clay Paky has not settled for merely producing a "more powerful beam light". The SUPERSHARPY also provides the utmost in terms of light quality and number of effects.

Let's start from the light quality. The SUPERSHARPY produces a **thick column of structured, dense light**, not just concentrated, but also with a clear and uniform color. This is the result of a new optical unit with a **large 170 mm diameter lens** at its end, from which a beam similar to a powerful searchlight emerges. The beam diameter can be modified with a **beam size reduction system**, offering different diameters right down to a "surgical" micro-beam similar to a laser. The brightness remains the same at any beam angle and the minimum aperture is literally **zero degrees**, i.e. the SUPERSHARPY's beam remains **perfectly parallel** for its entire length.



A **frost unit** allows to soften the beam edge, to such an extent that SUPERSHARPY nearly turns into a wash light. Let's now look at the effects, starting with the colors. The SUPERSHARPY features a **CMY mixing system** based on 3 gradually fading color wheels. The dichroic filters have been selected and combined to produce a nearly infinite variety of hues and shades. **Two CTO filters** (3,200 K and 2,500 K) and **one CTB filter** are available on each wheel to create even the "warmest" shades.

The SUPERSHARPY features **two gobo wheels**. The first has 7 high quality rotating dichroic gobos; the second provides 18+1 fixed metal gobos, including a wide selection of **beam diameter reducers**. The gobos can be used to shape the beam in mid-air but, in addition and thanks to the extraordinary SUPERSHARPY optics, perfectly focused images can be projected onto the projection surface, even tens of metres away! Lastly, an **8-facet rotating prism** features volumetric light scattering.

Let yourself get hooked on the SUPERSHARPY, its surprising speed and the fluidity of its movements. The legend continues...



### CMY COLOR WHEELS

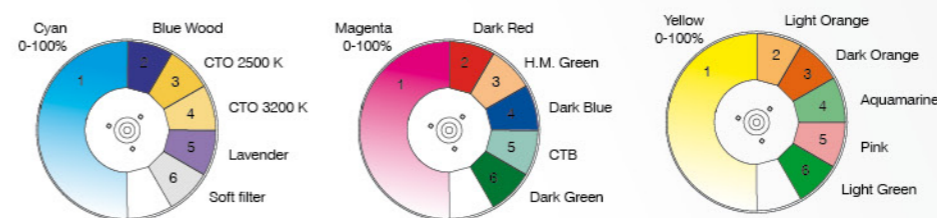

### GOBO WHEEL

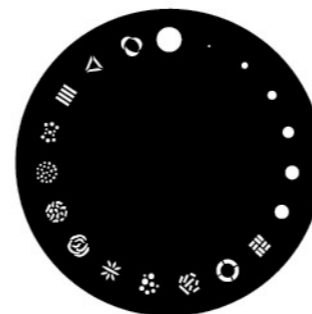

### WEIGHT AND DIMENSIONS (mm/inches)

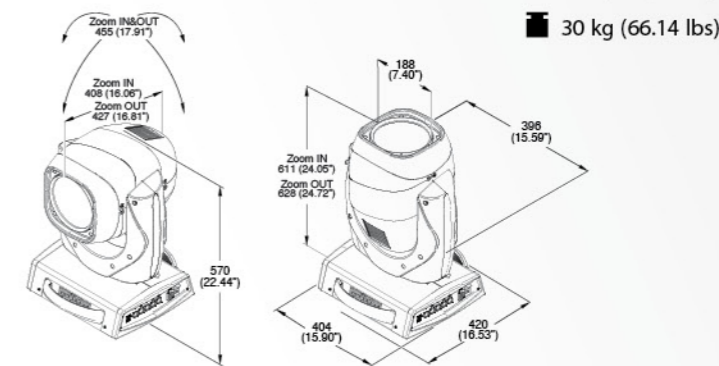

### ROTATING GOBOS Ø 25.7 mm - img: Ø 16 mm



## STORMY

THE LATEST LED TECHNOLOGY MEETS THE CHARM OF A CLASSIC STROBE

STORMY: CODE C71090  
STORMY CC: CODE C71091



STORMY innovates tradition since it uses the latest LED technology, but retains all the charm of a classic strobe.

The light source is a strip of powerful white LEDs with a 5,700 K color temperature; thanks to their linear arrangement, they **perfectly emulate a bright Xenon linear lamp**.

The flash effect is actually enhanced since the Stormy is equipped with a parabolic reflector, like a classic strobe, and does not project the light directly forwards, like other LED strobes do. The reflector collects the main **beam over an aperture of 42°, leaving 130° for spatial diffusion**. Its total brightness is a remarkable **80,000 lumens**.

Using LED technology has another important benefit: the flash effect management is enormously flexible. The frequency, duration and intensity of the pulse are **fully digitally controlled**, and these parameters are even independently adjustable, which is impossible with a xenon lamp strobe.

When it "pulsates", the Stormy delivers 980 watts. Thanks to its highly sophisticated electronics, the light turns on and off instantly, creating the **jerky movement illusion**, which is the essential hallmark of a true strobe.

The time the light is on (the pulse duration) may be extended as required. In this case, the Stormy delivers 720 watts with automatic adjustment. Thanks to the use of LEDs, the light intensity remains absolutely constant, **without flickering effect** found with conventional strobes.

Besides the **white LED version**, the Stormy also comes with **RGBW LEDs** (STORMY CC), which are able to flash in any color. At last, there is no more need for gels, which dramatically reduce the amount of light, or slow noisy unreliable scrollers.

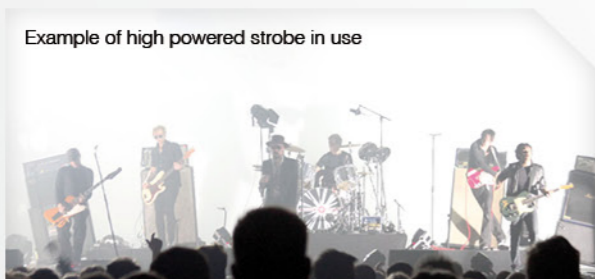

The way the strobe pulse is controlled is the same as was described for the white LED version. The STORMY CC has a total brightness of 40,000 lumens.

With the Stormy, the age of dinosaurs is over. The striking effect of a true classic strobe in a modern technology package is finally available. The fragile lamps that last only 500 hours have been replaced by sturdy LEDs, which last **over 50,000 hours**. The light pulse may be adjusted freely with absolute precision. You can get flashes of colored light. A modern digital display means the parameters and DMX address may be set up in an immediate, user-friendly way.



### WEIGHT AND DIMENSIONS (mm/inches)

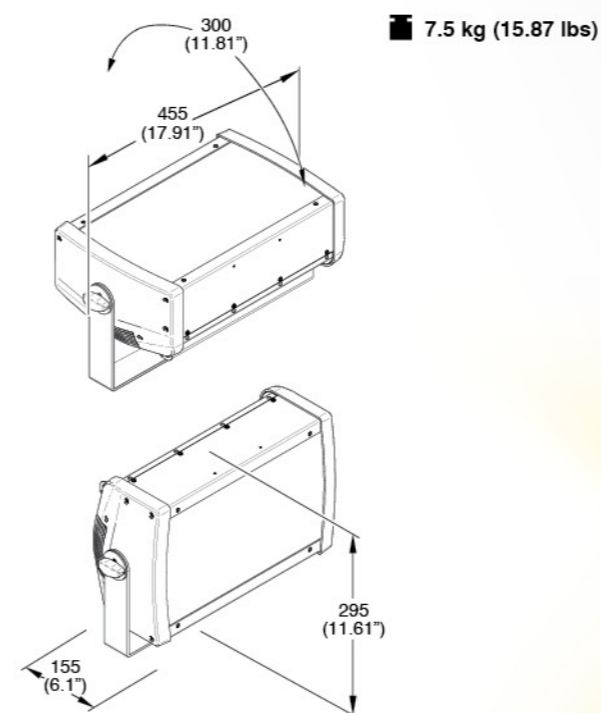

Optional adjustable barndoors (CODE C71116) are available for both STORMY and STORMY CC

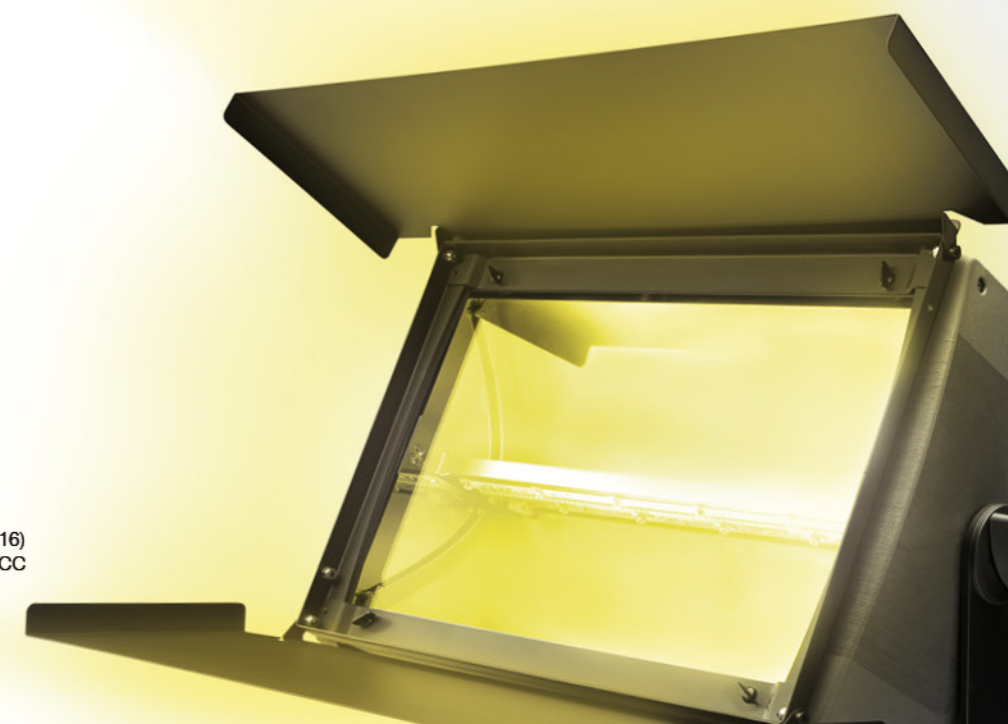

**WWW.THEPROJECTORS.IT**



**SUPER  
SHARPY**



**MYTHOS**



**STORMY**



AN OSRAM BUSINESS

CLAY PAKY S.p.A. - I - 24068 Seriate (BG) - Via Pastrengo, 3/b - Phone +39 035 654311 - Fax +39 035 301876  
[www.claypaky.it](http://www.claypaky.it) - [info@claypaky.it](mailto:info@claypaky.it)